

Assembly Manual / Guide d'assemblage /
Manual de ensamblaje / 조립설명서 /
Montageanleitung

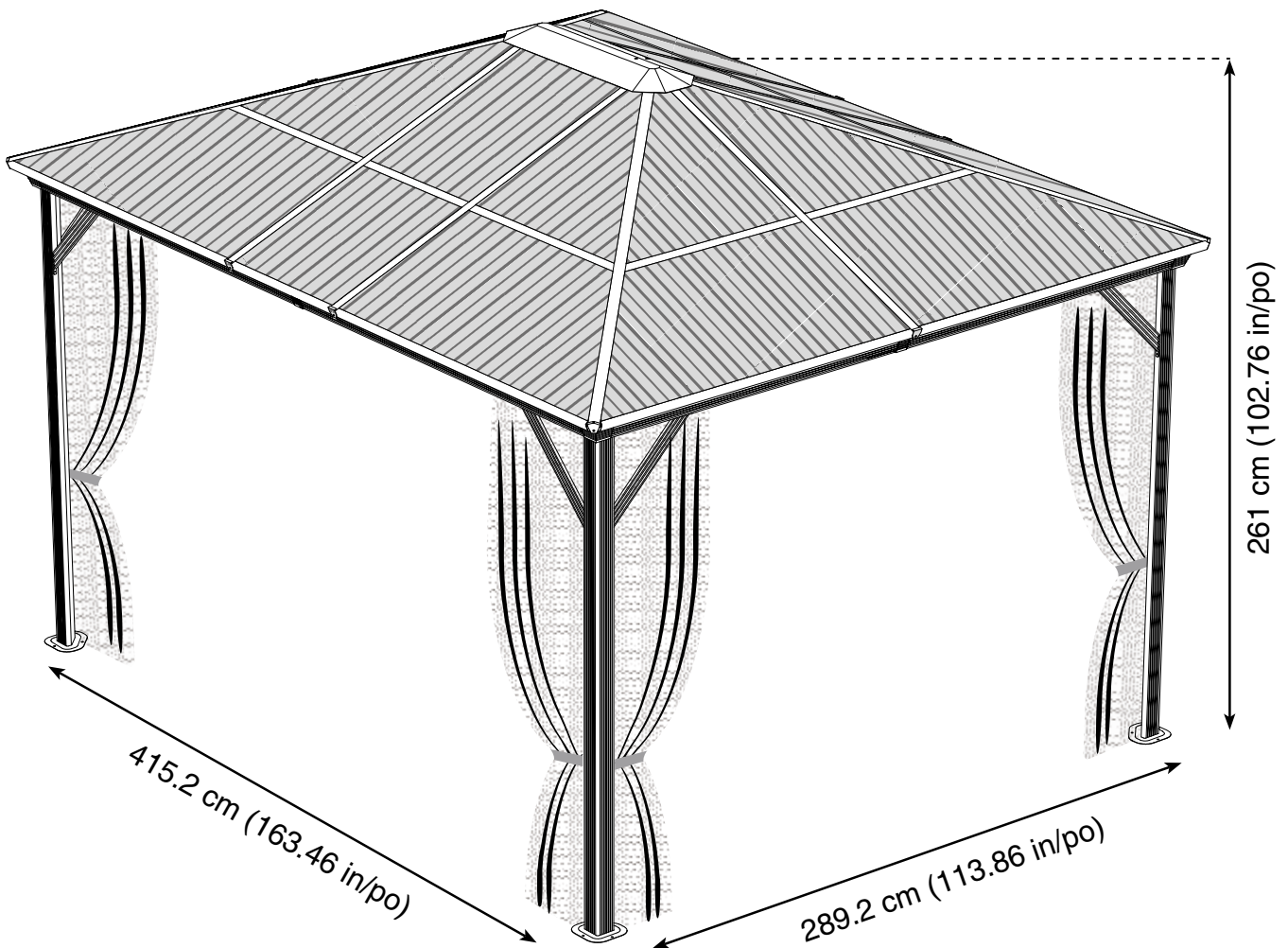

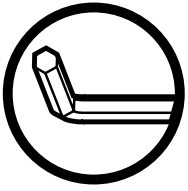

Use the hex keys in the box. / Utilisez les clés hexagonales fournies dans la boîte. /
Utilice las llaves hexagonales en la caja. / 상자에 육각 키를 사용 하십시오. / Verwenden Sie
die Sechskantschlüssel in der Box.

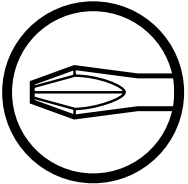

Please use a Phillips screwdriver. / Utilisez un tournevis de type Phillips / Por favor,
use un destornillador Phillips. / 십자 드라이버를 사용 하십시오. / Bitte verwenden
Sie einen Kreuzschraubenzieher.

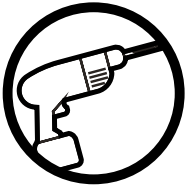

You may need to use a drill for this step. / Vous pouvez avoir besoin d'utiliser une
perceuse pour cette étape. / Puede que tenga que utilizar un taladro para este paso. /
이 단계에선 드릴을 사용해야 할 수도 있습니다. / Für diesen Schritt können Sie einen
Bohrer verwenden.



Wearing protective gloves is recommended. / Le port de gants de protection est recommandé /
El uso de guantes de protección se recomienda. / 보호 장갑을 착용 하는 것이 좋습니다. /
Das Tragen von Schutzhandschuhen wird empfohlen.



Two or more people are required at this stage. / Deux personnes ou plus sont nécessaires à cette
étape. / Dos o más personas se requieren en esta etapa. / 이 단계에서는 두 명 이상 이 필요합니다. /
Für diesen Bauschritt sind 2 oder mehr Personen erforderlich.



Do not tighten screws all the way for now. / Ne pas visser fermement pour l'instant. /
No atornille con firmeza por ahora. / 아직 나사를 단단히 조이지 마십시오. / Bitte die
Schrauben zum jetzigen Zeitpunkt noch nicht fest anziehen.



Sold separately. / Vendus séparément. / vendido en las opciones. /
옵션 판매 / Optional erhältlich

T X 8 (+2)

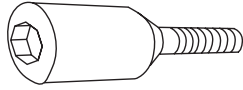

U X 16 (+2)

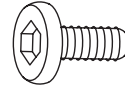

U1 X 1 (+1)

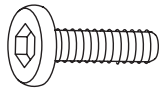

U2 X 2 (+1)



V X 72 (+7)

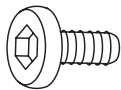

V1 X 16 (+2)

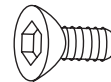

V2 X 20 (+2)

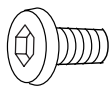

W X 24 (+4)

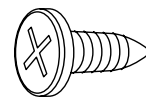



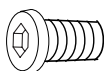



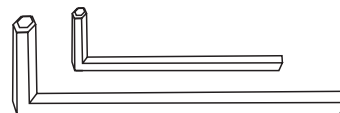

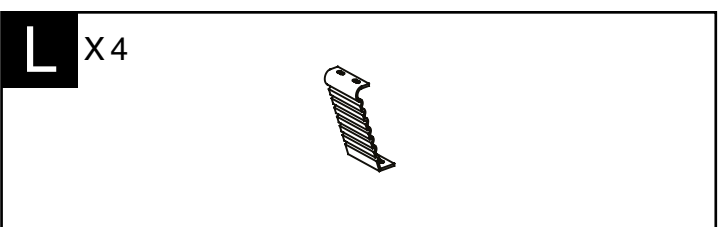
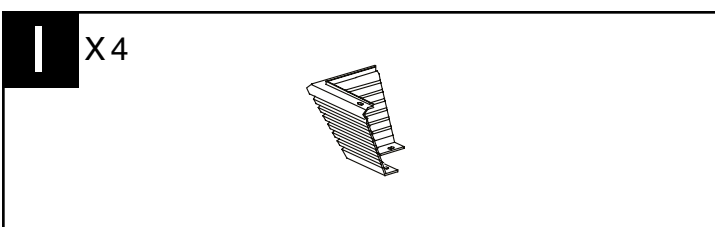
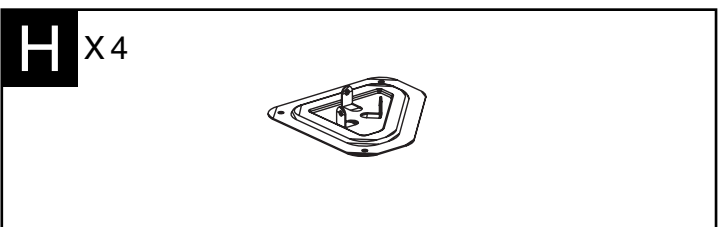
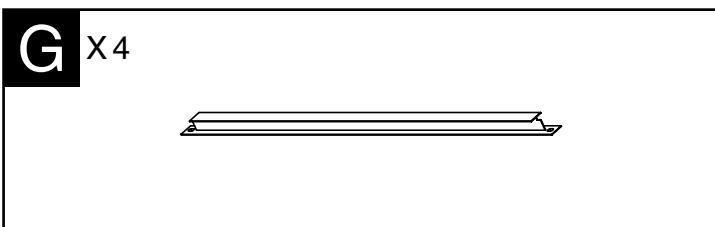
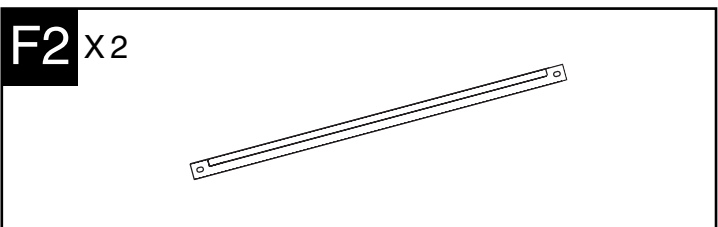
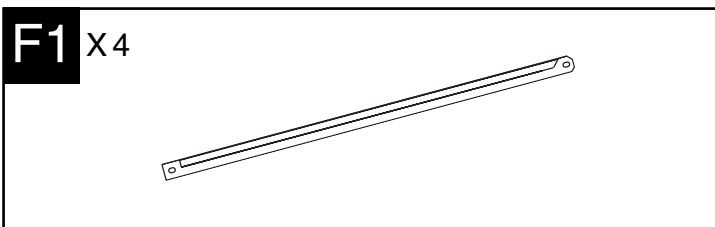
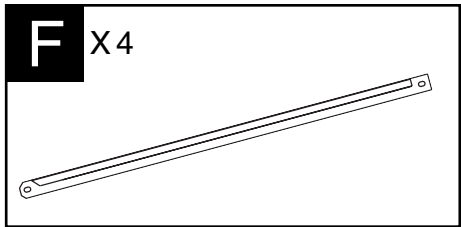
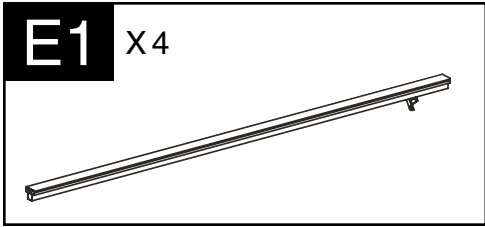
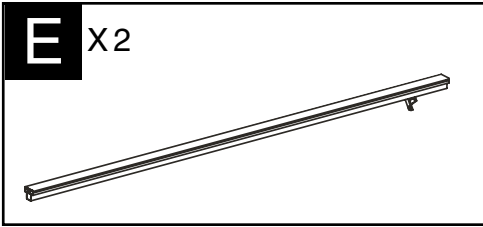
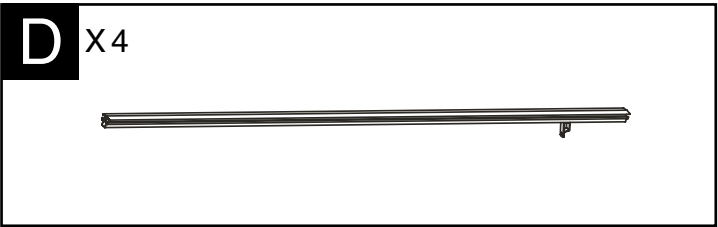
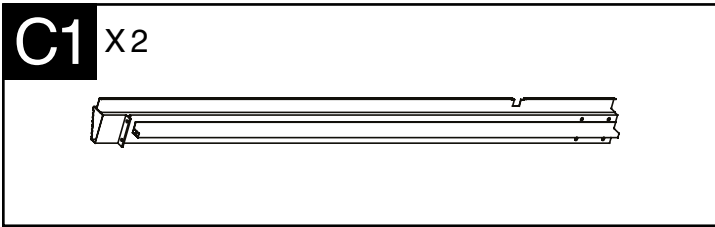
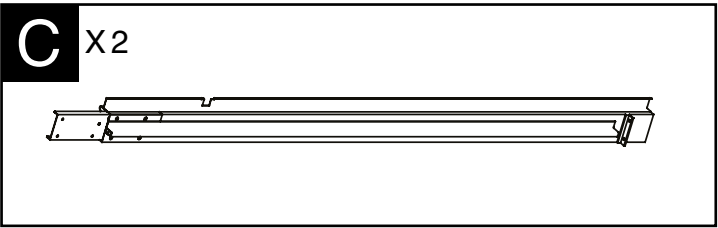
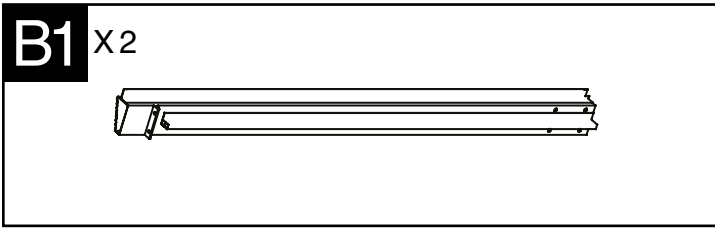
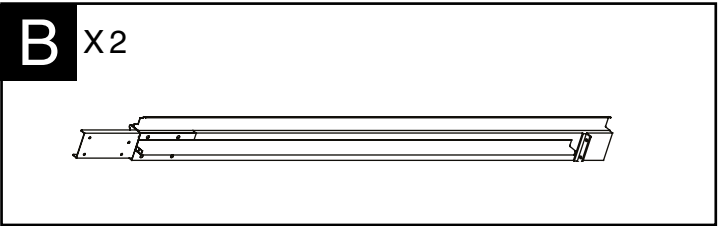
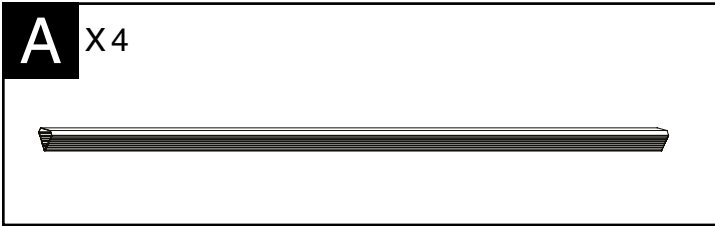

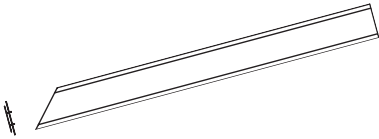
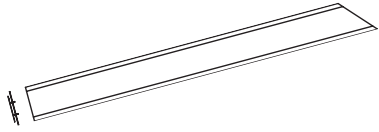
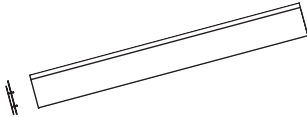
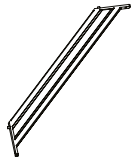
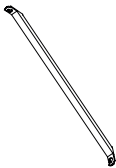

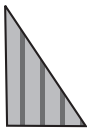
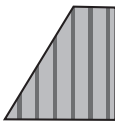
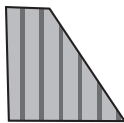

W1 X 16 (+2)

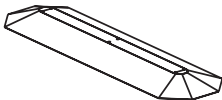
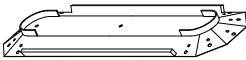

Y X 1

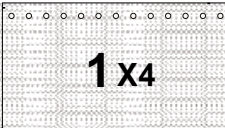

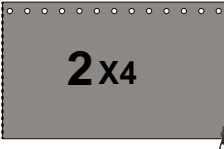

J X4 	J1 X4 	
J2 X2 	K X8 	
K2 X4 	Ma X4 	
Na X4 	Mb X4 	
Nb X4 	Z X2 	Z1 X2 
Q X4 	R X6 	S X1 
S1 X1 	X X 56(+2) optional   	
Net  1 X4 	Curtain  2 X4 	

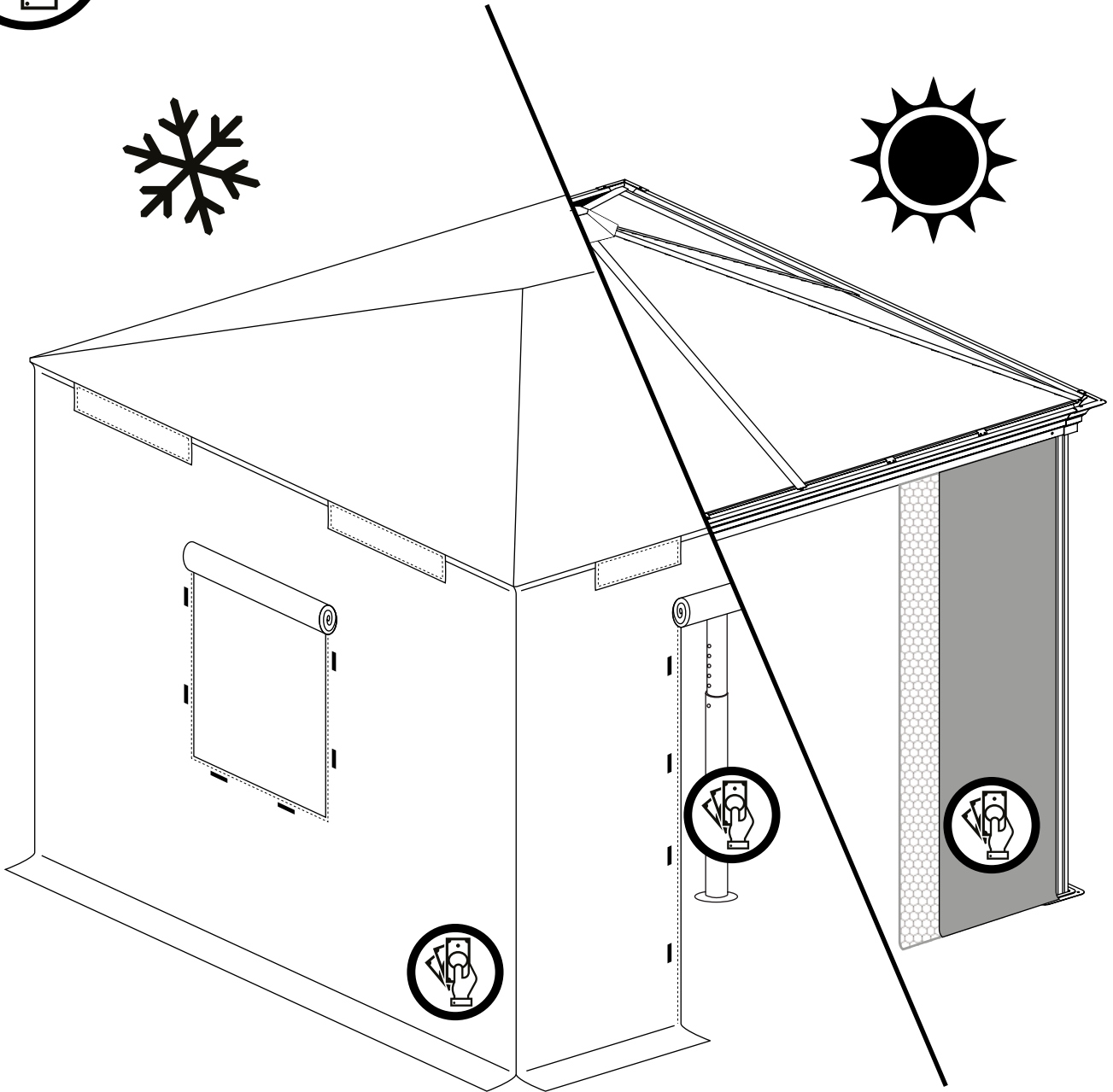
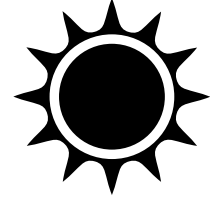
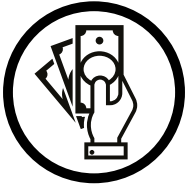

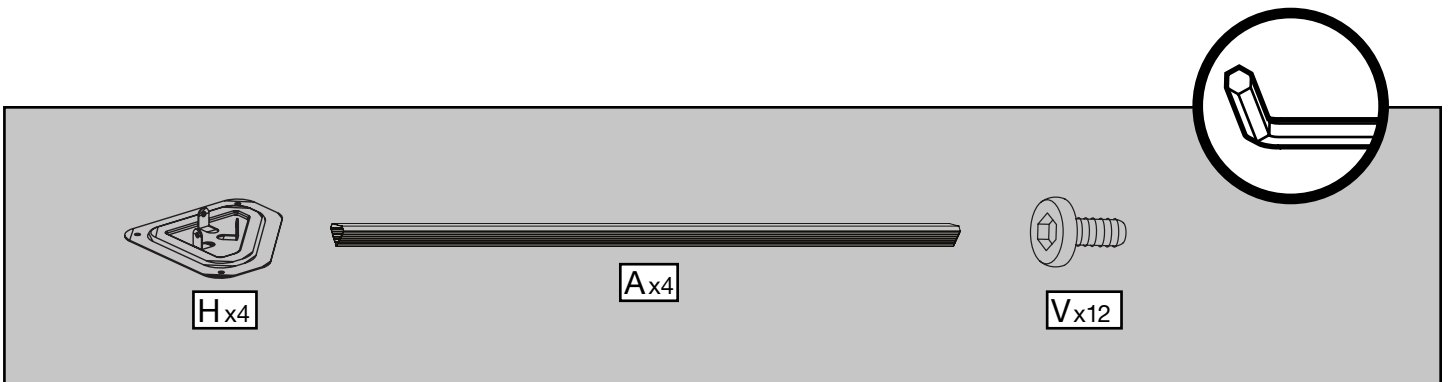
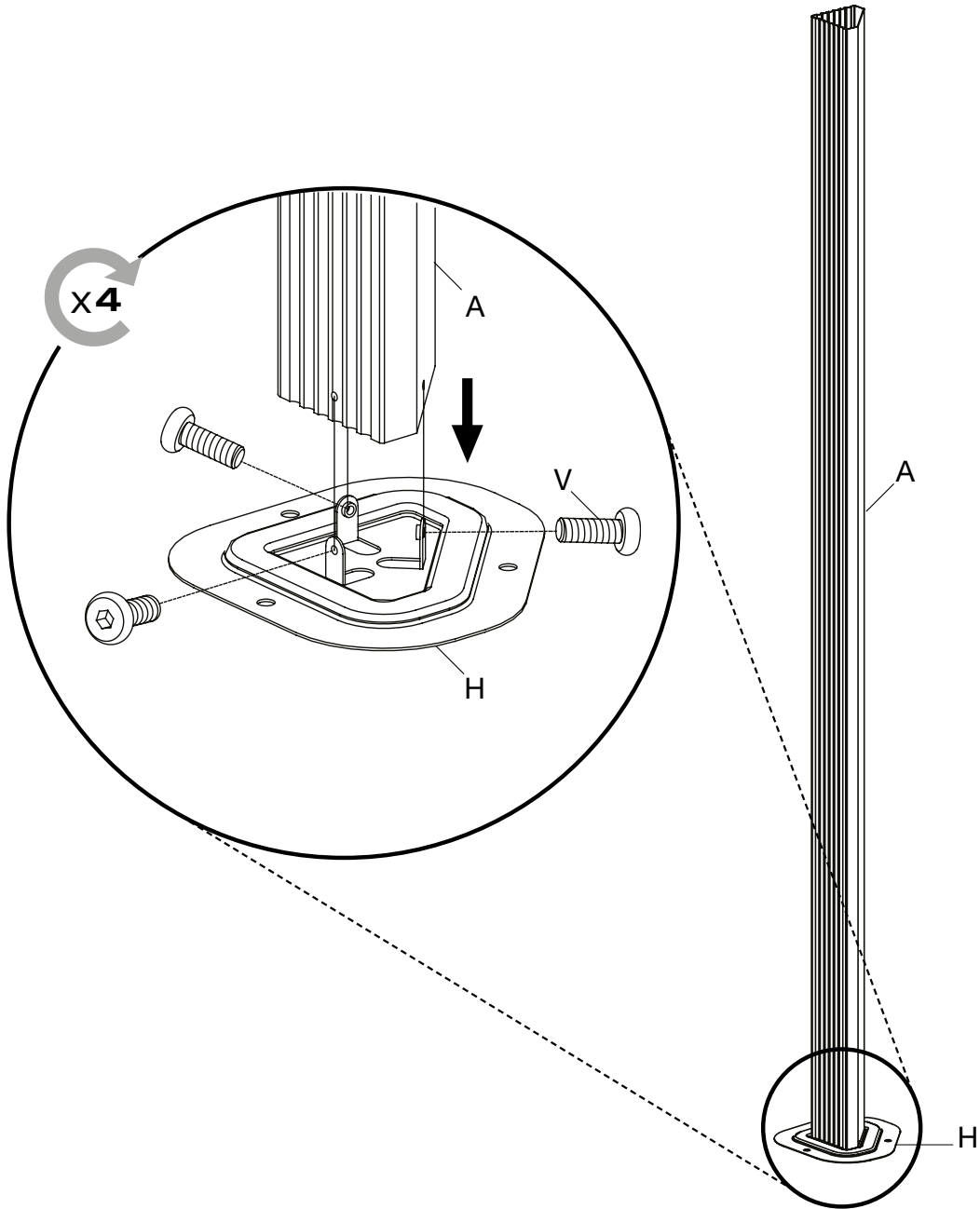

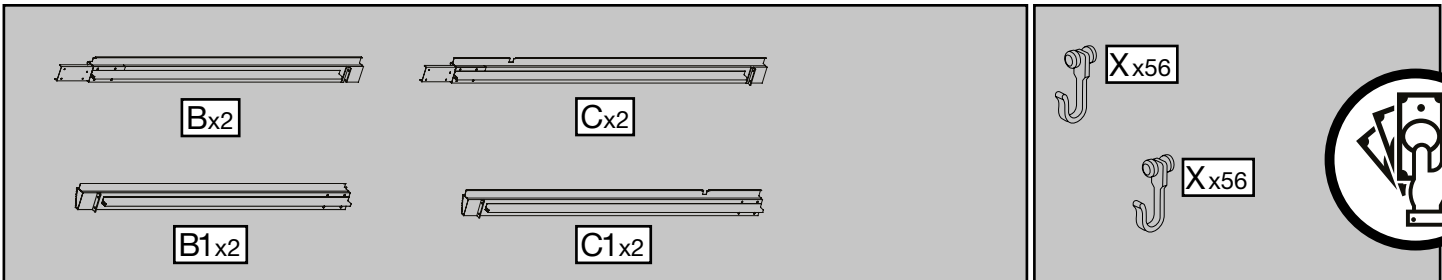
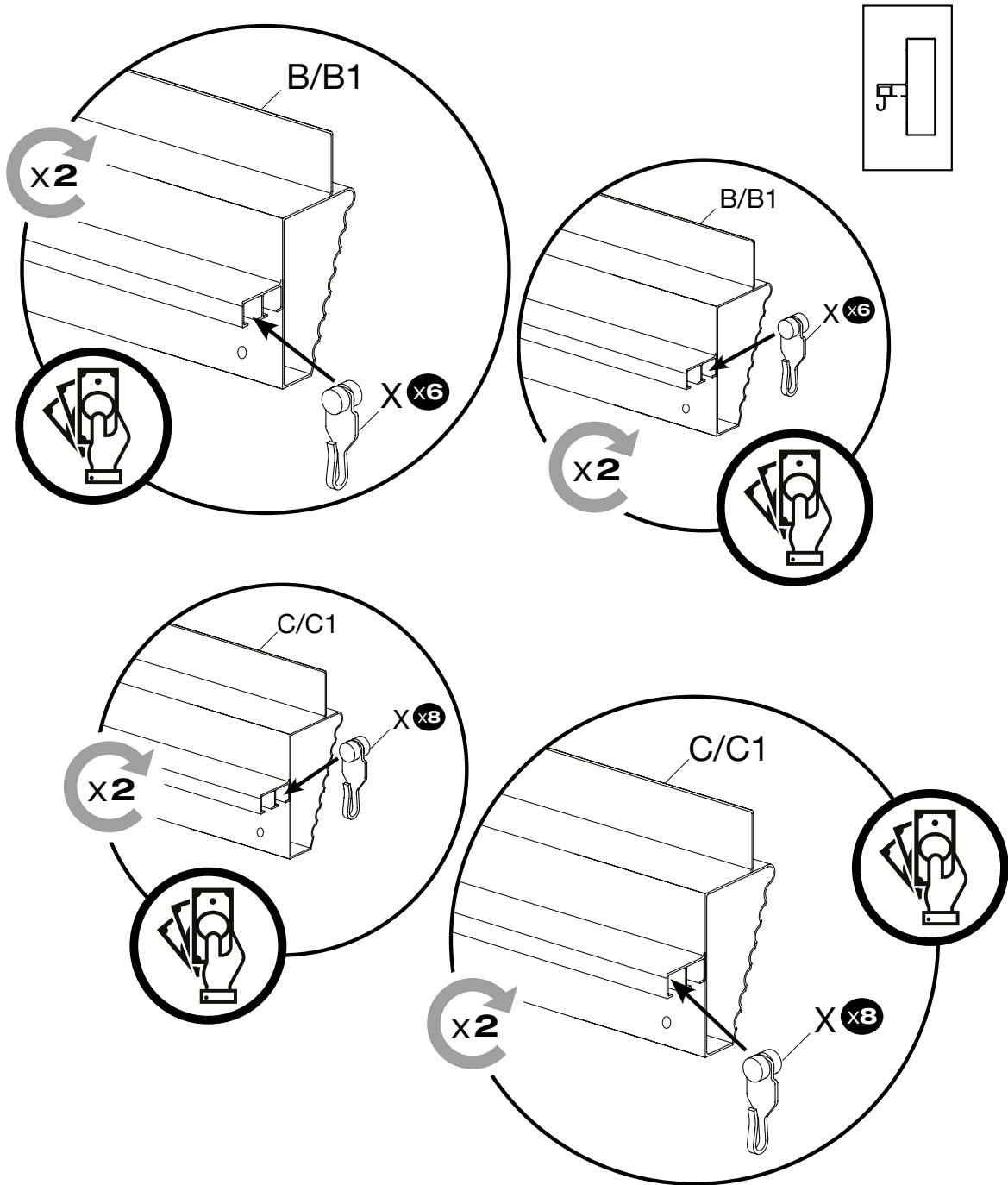

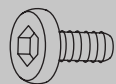
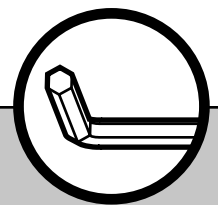
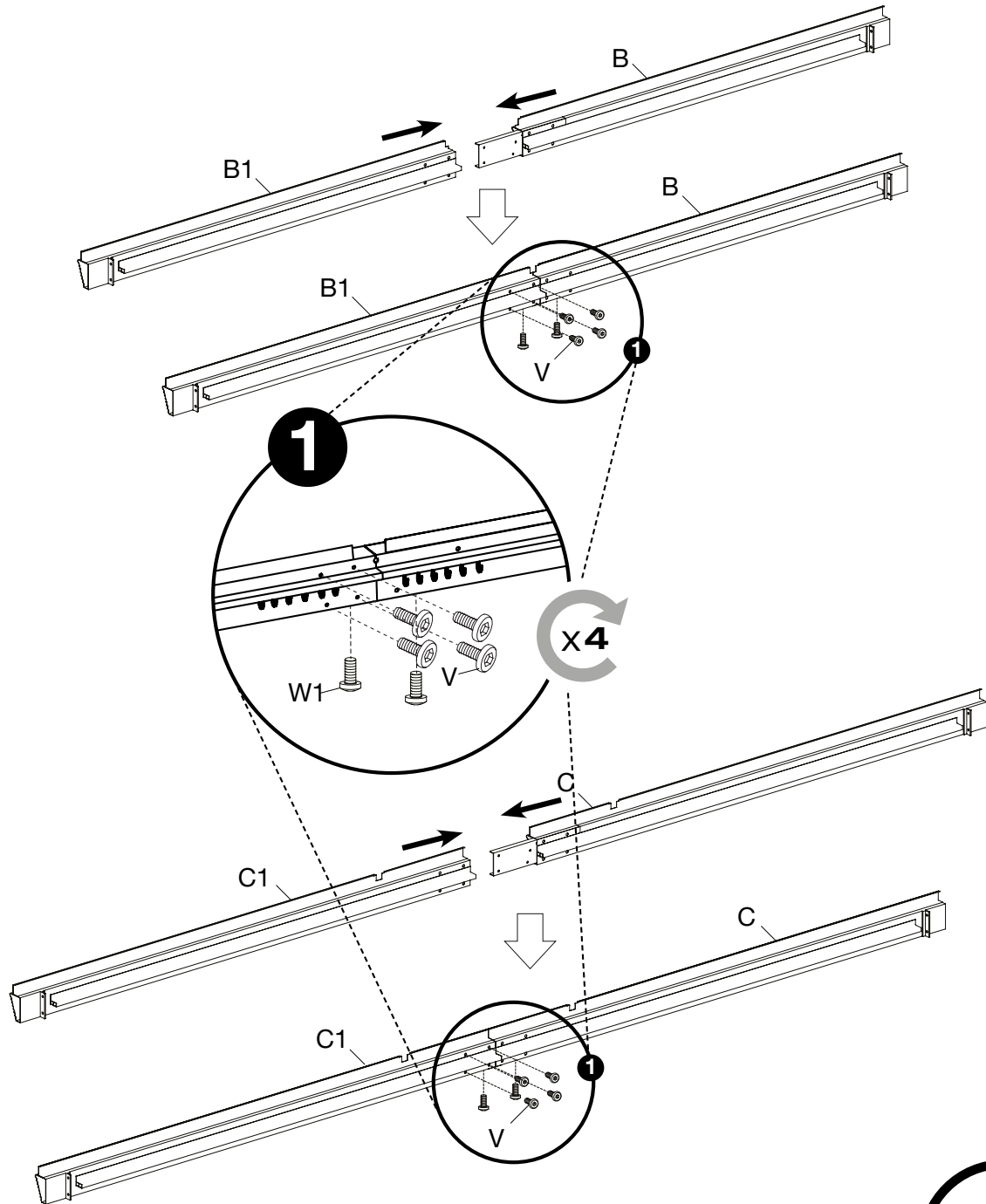

Vx16



W1x8

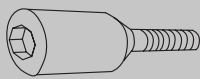
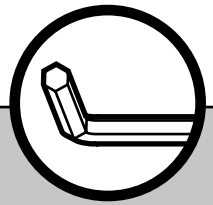
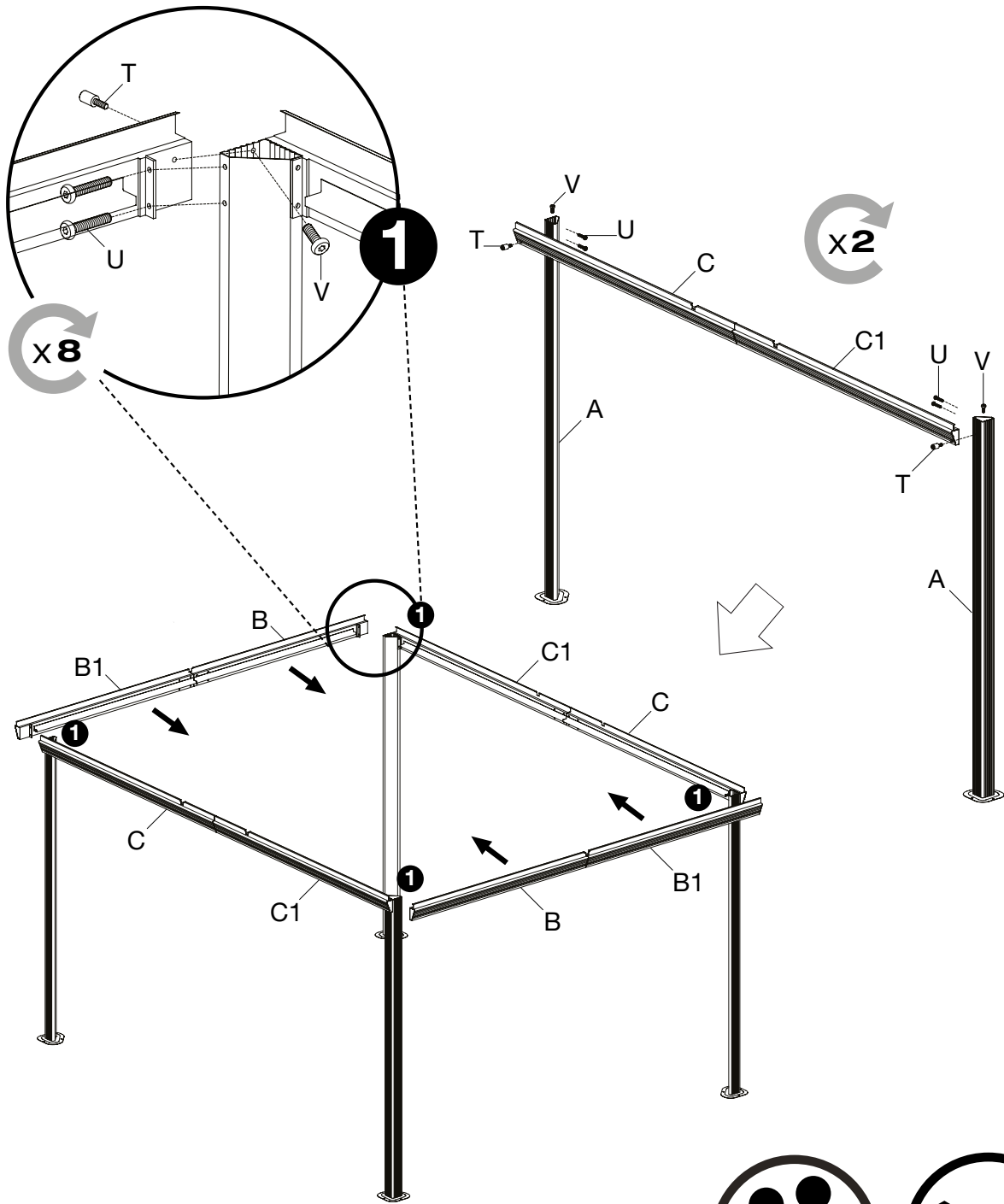

T x8

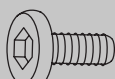

U x16

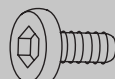

V x8

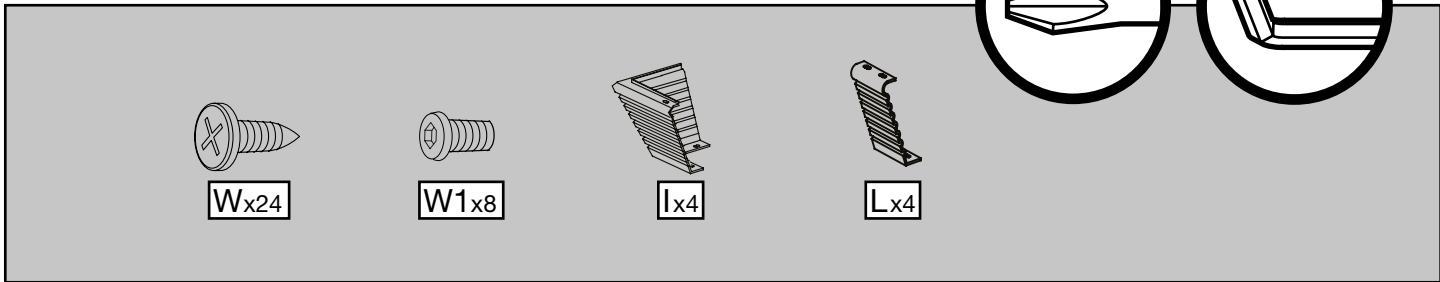
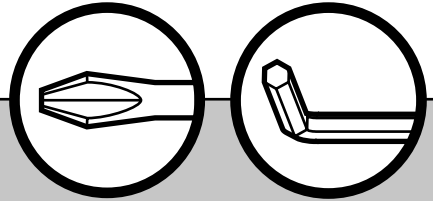
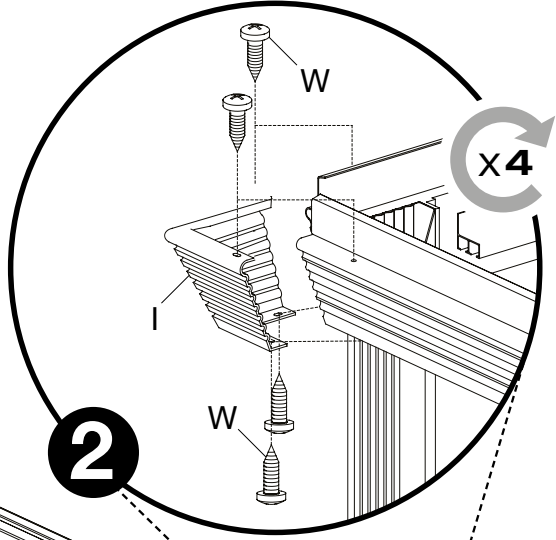
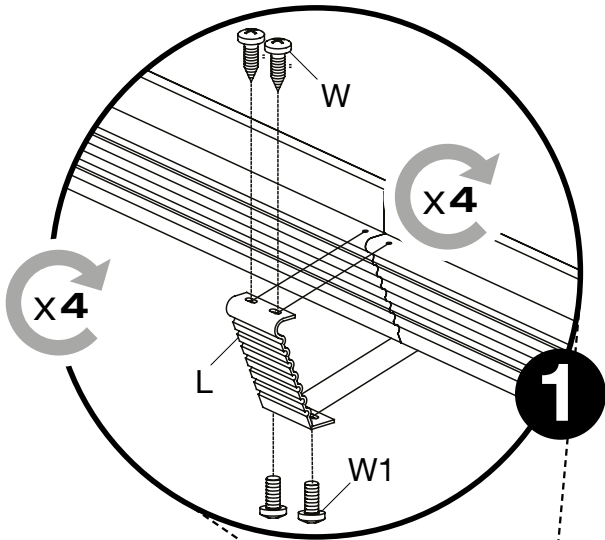
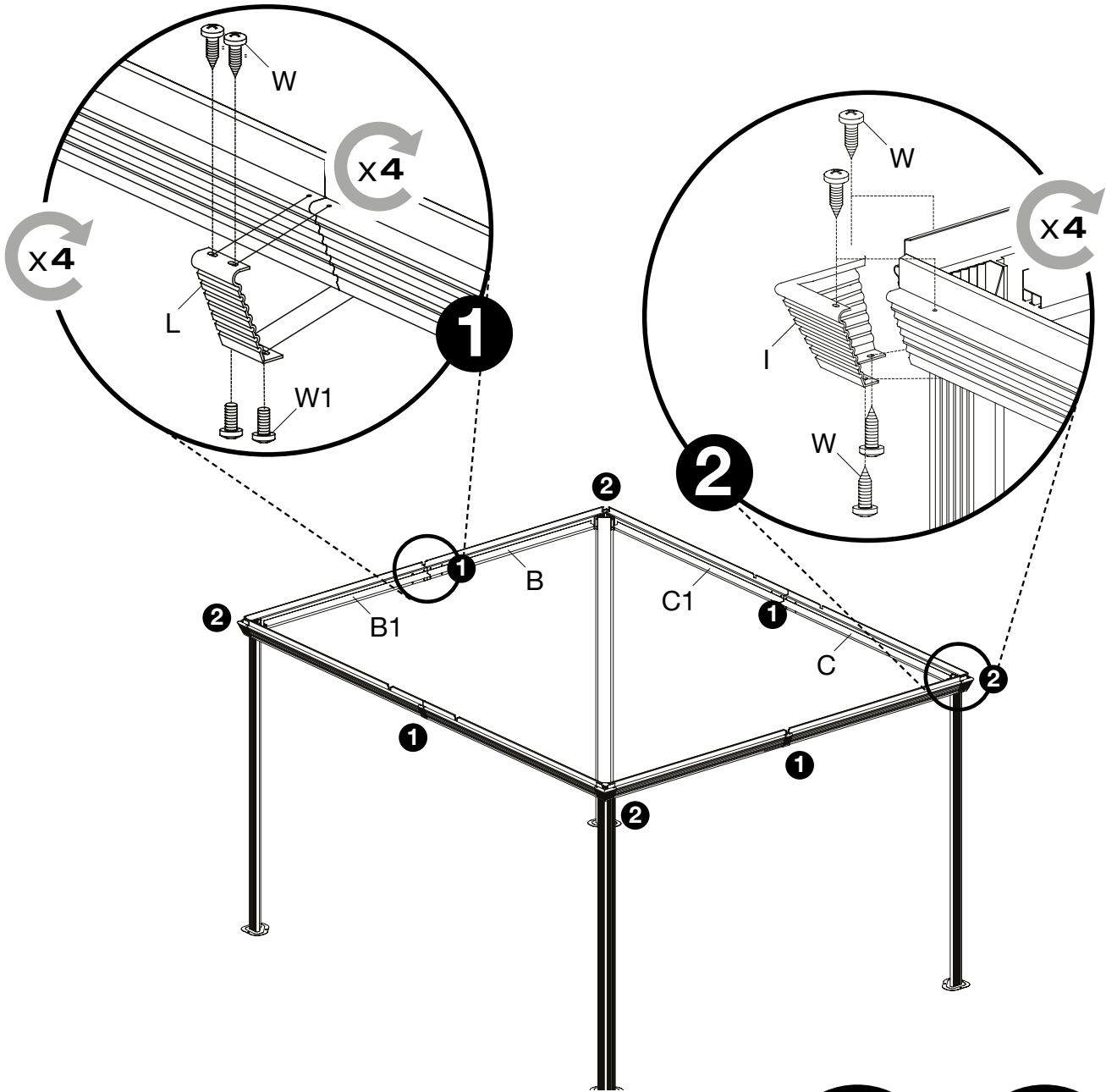

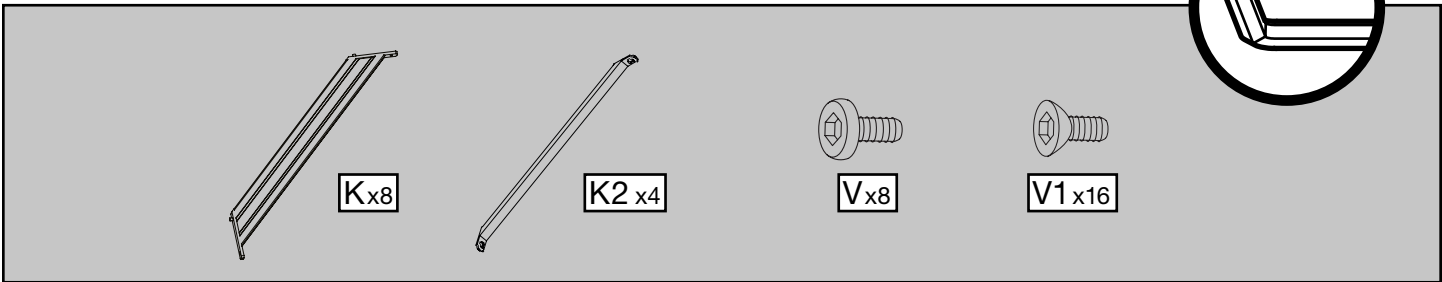
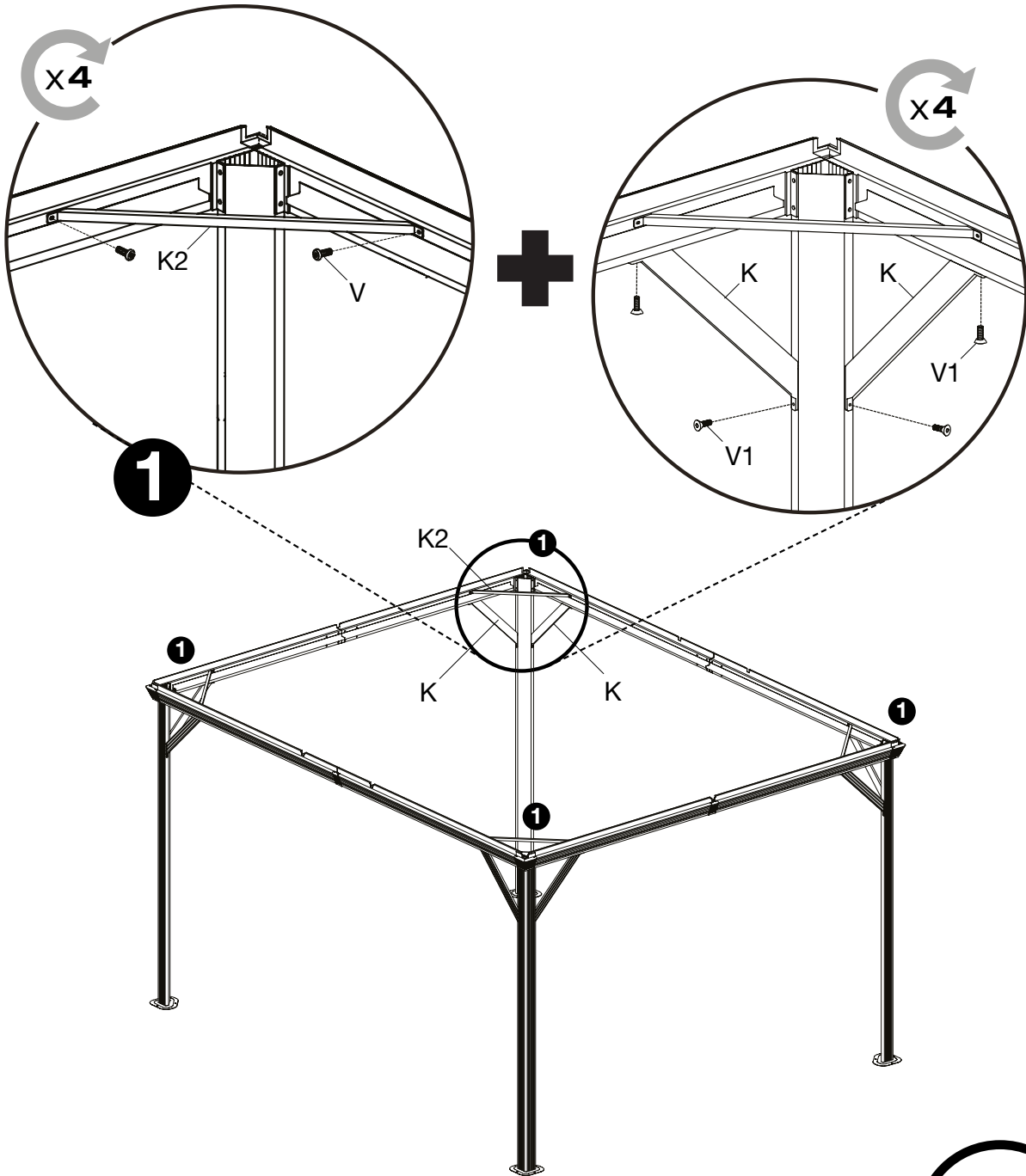

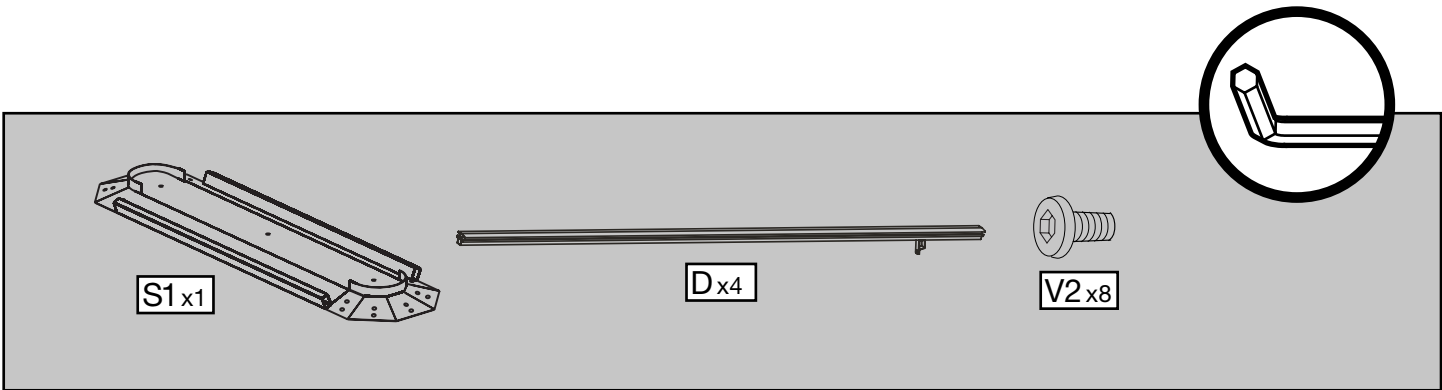
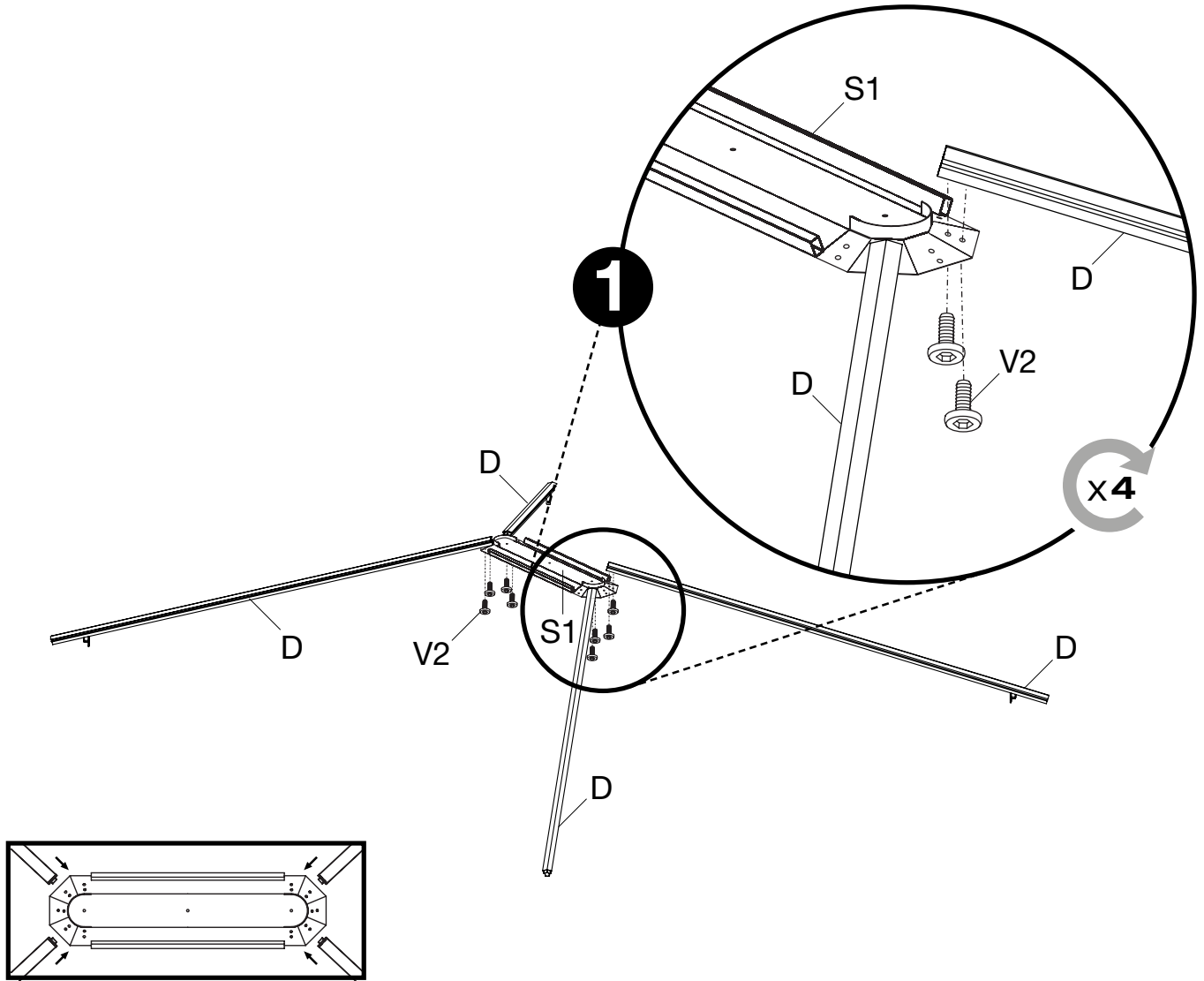

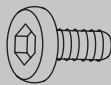
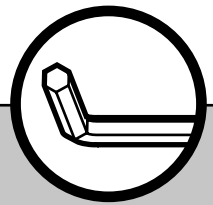
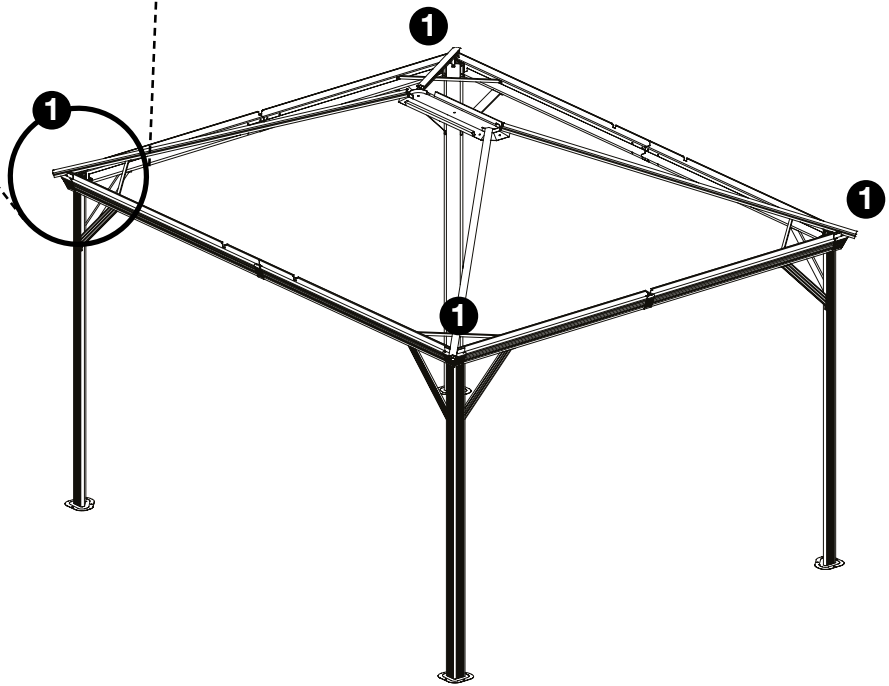
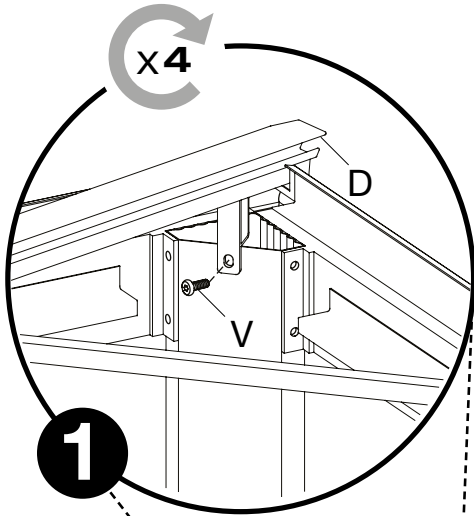

Vx4

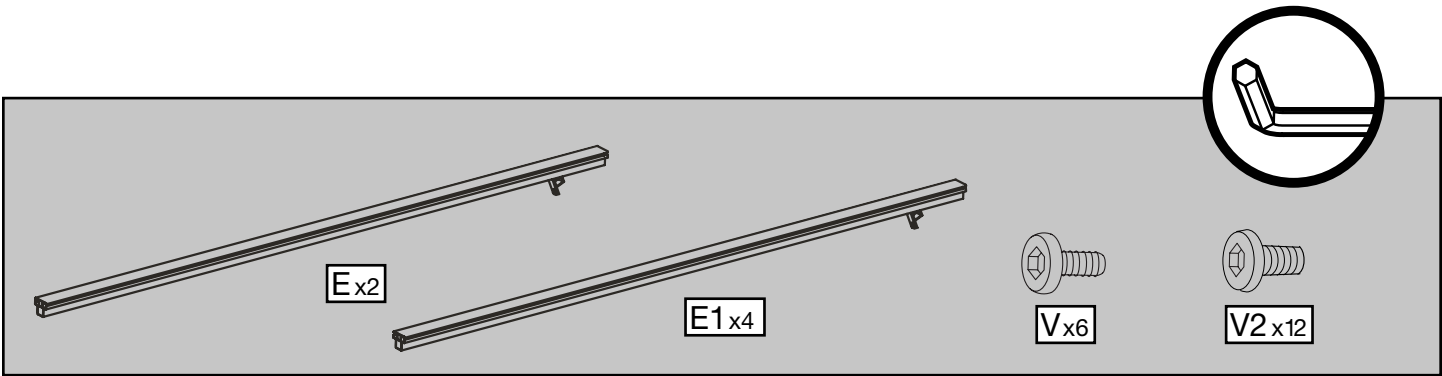
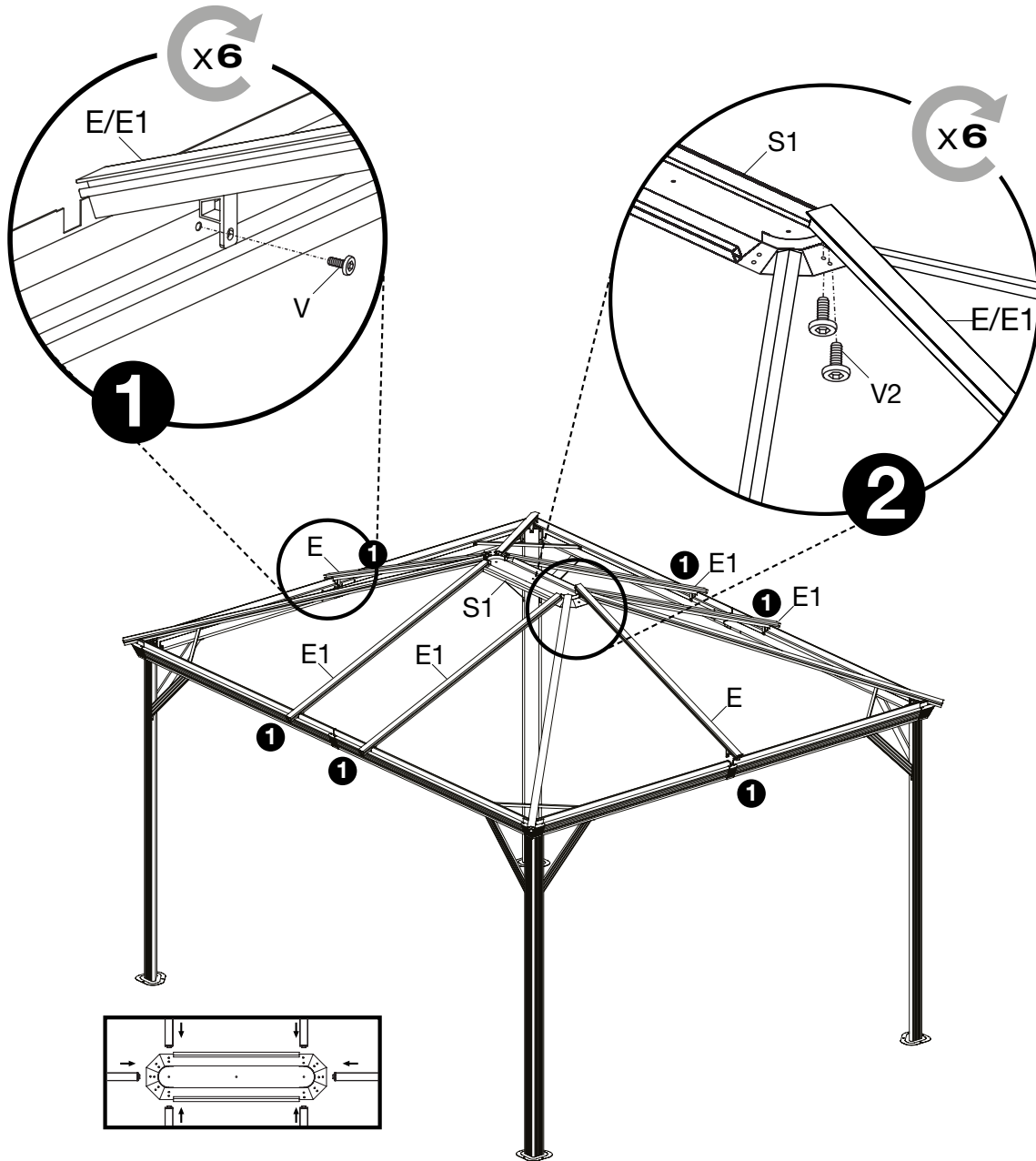

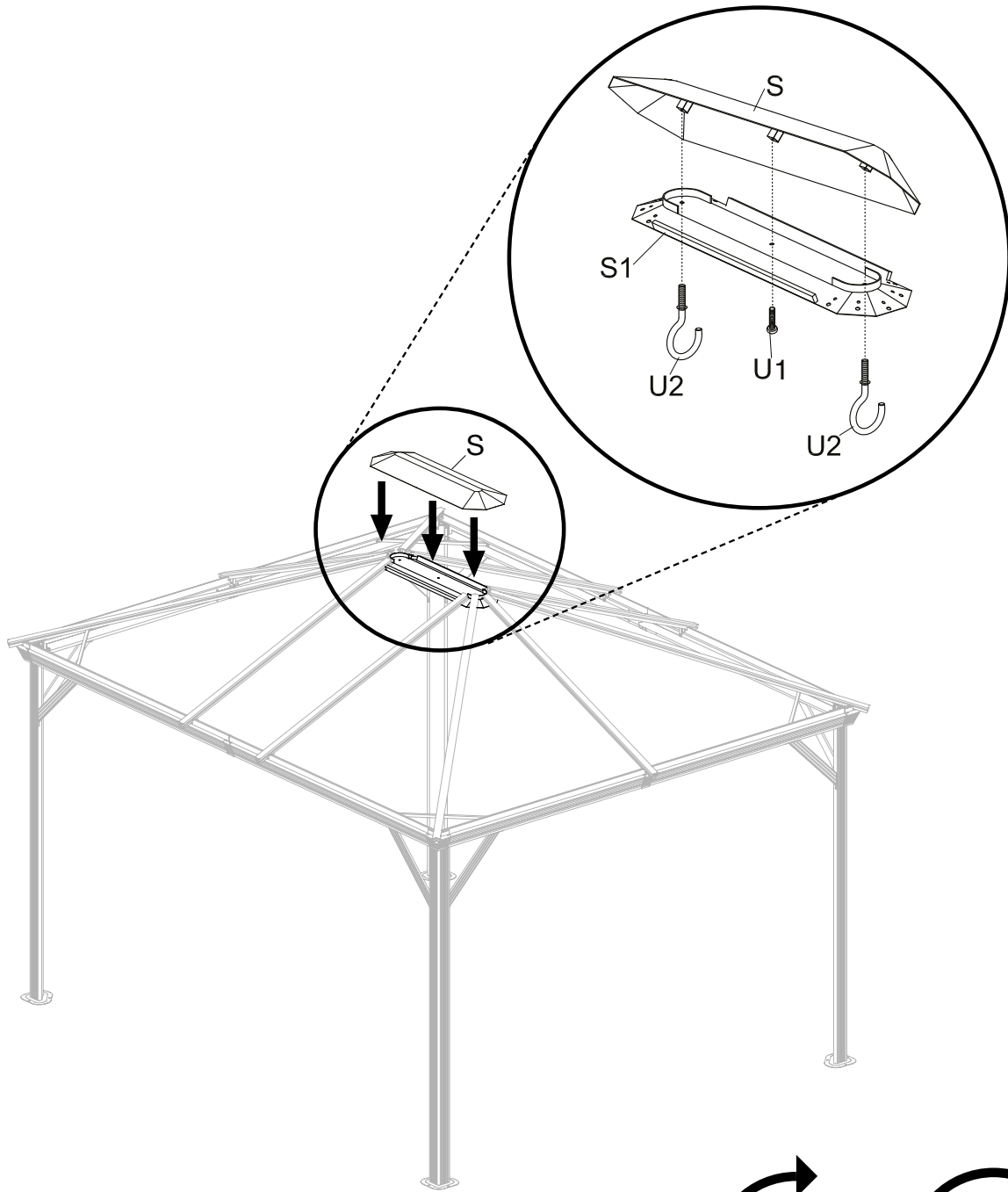

This section contains the parts list and safety icons for step 16. On the left, there are three items: a long metal rail labeled 'Sx1', a bolt labeled 'U1 x1', and a hook labeled 'U2 x2'. To the right of the parts list are two circular icons: the first is a hand with a diagonal line through it, indicating a warning or prohibition; the second is a circular icon showing a hook being inserted into a rail, illustrating the correct installation method.

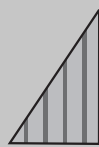
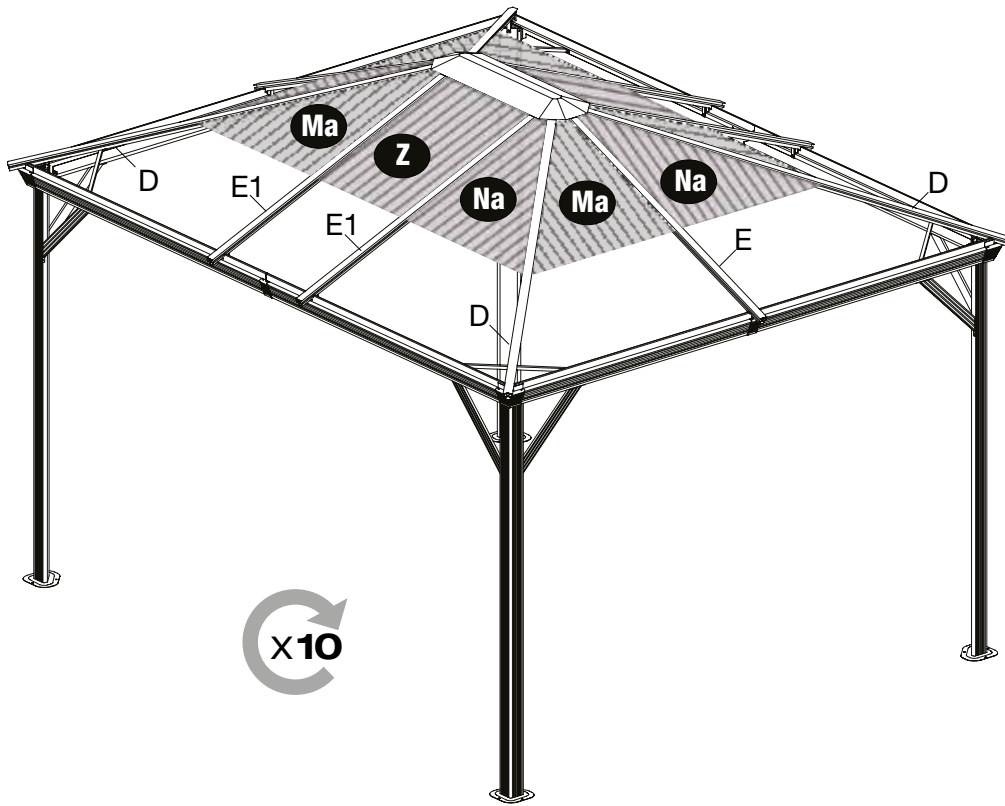
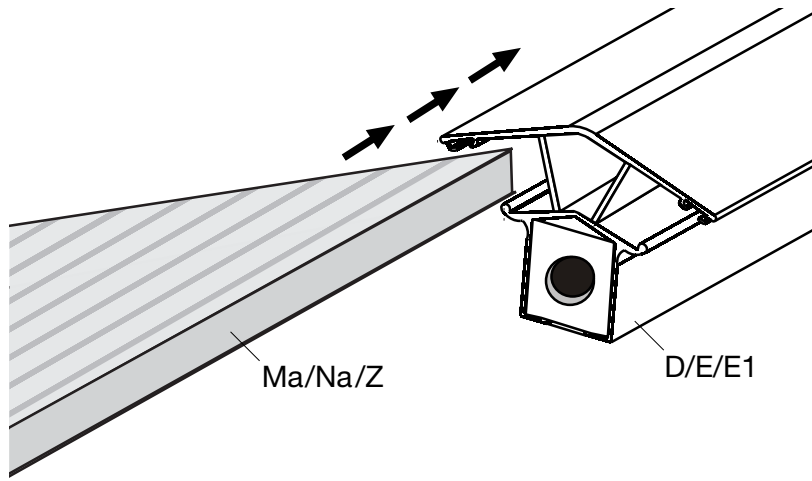

Ma x4



Z x2



Na x4

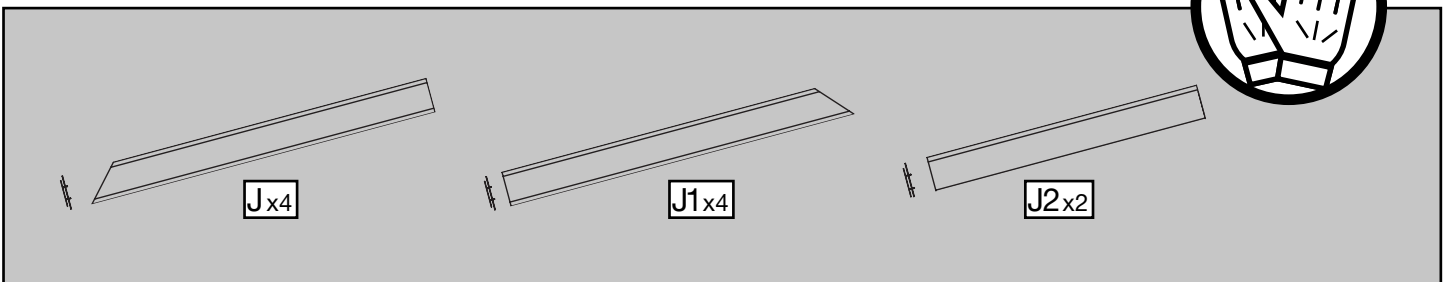
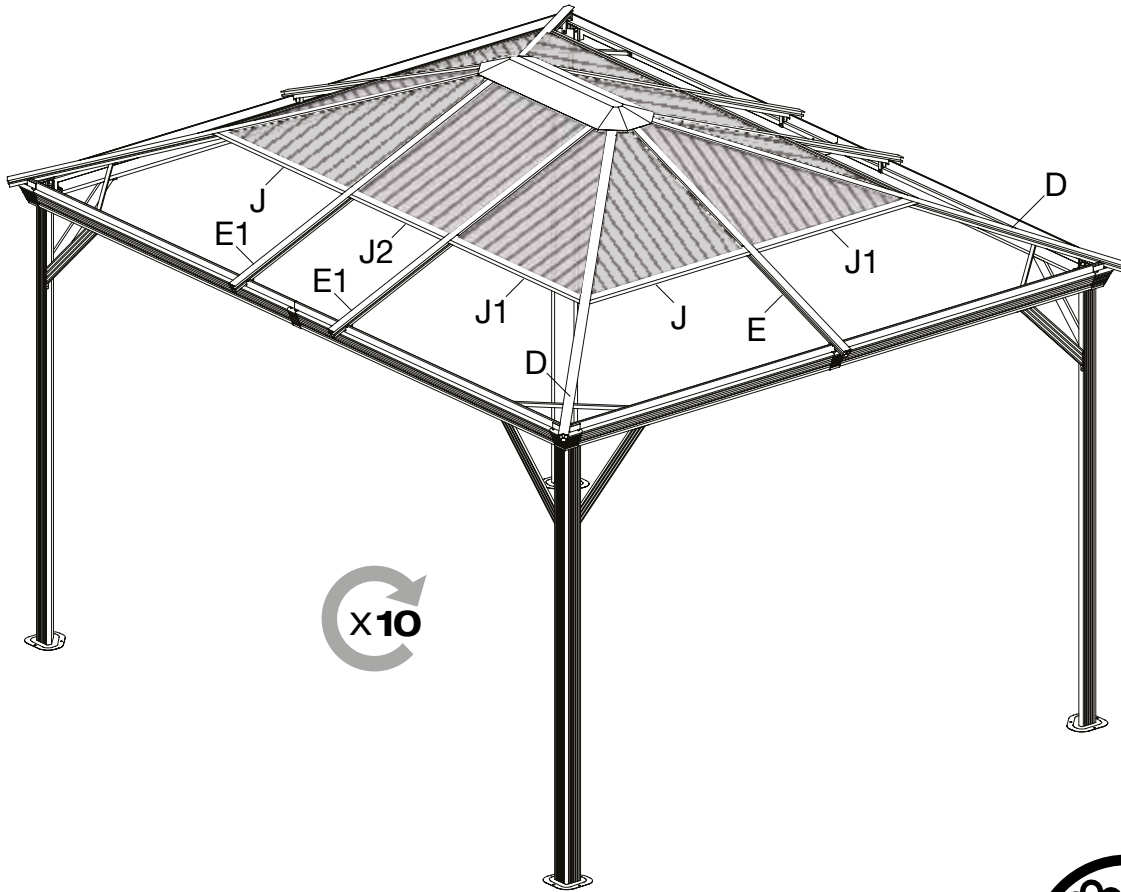
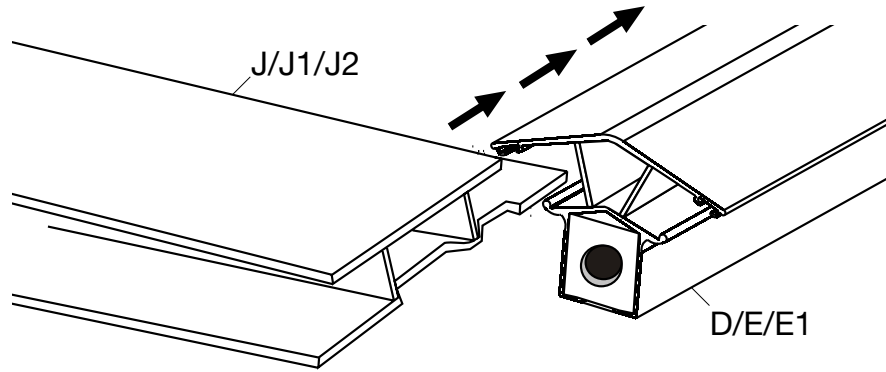

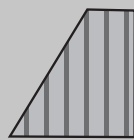
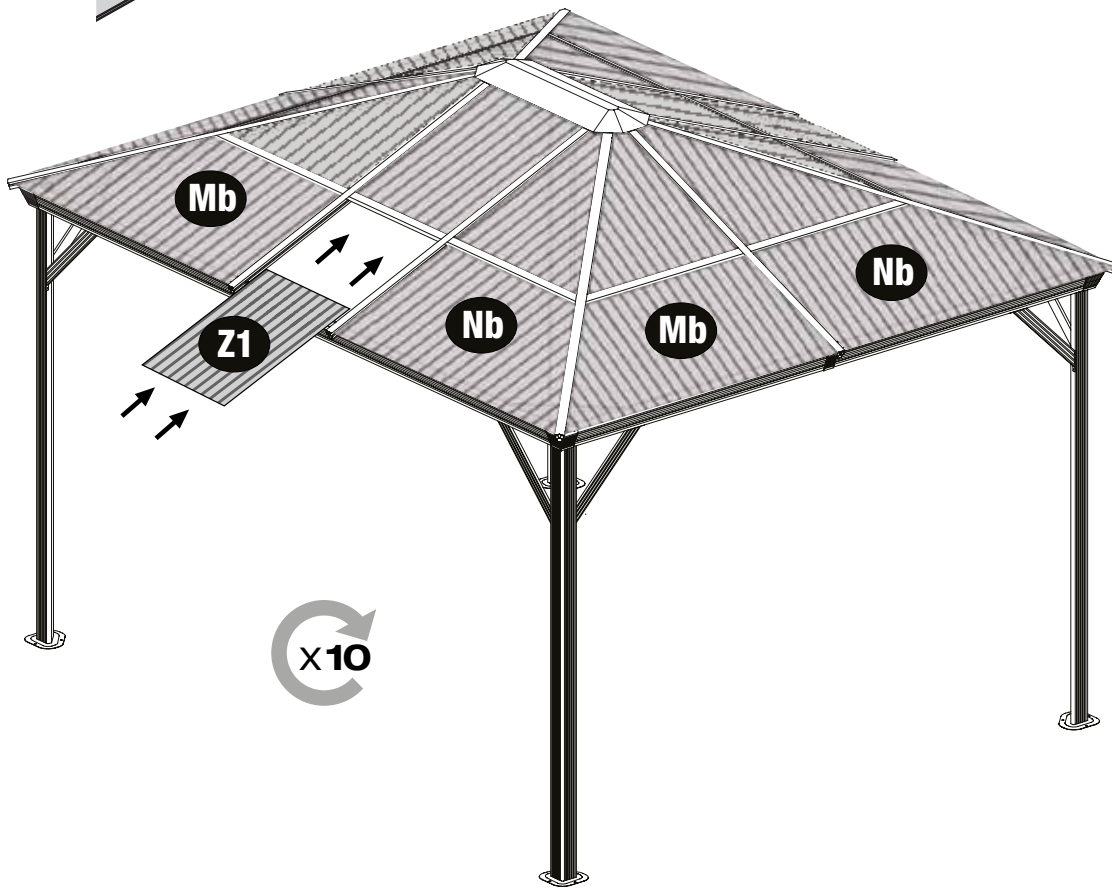
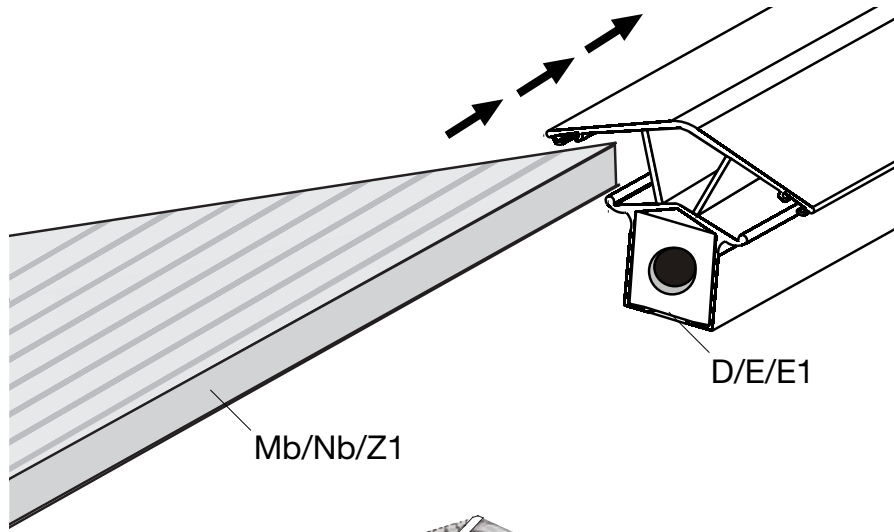

Mb x4

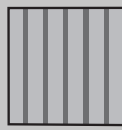

Z1 x2

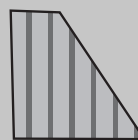

Nb x4

